

**MATHEMATICS FOR THE INTERNATIONAL STUDENT  
MATHEMATICS HL (CORE) WORKED SOLUTIONS  
(as at 28 February 2008)**

page 273 **Exercise 11G**

**13 d** length of belt  

$$= 2 \times \sqrt{20^2 - 2^2} + \frac{\theta}{360} \times 2\pi \times 4$$

$$+ \frac{\phi}{360} \times 2\pi \times 6$$

$$= 71.62$$

page 288 **Exercise 13B.1**

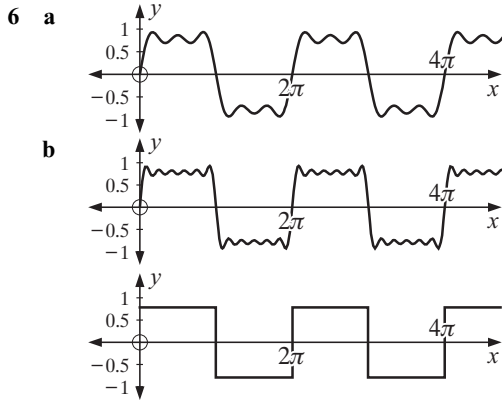

page 290 **Exercise 13C**

**2 a** Solution should finish:  
 At min.,  $t = 2$ , and at max.,  $t = 2 + 12 = 14$   
 $\therefore C = \frac{7+14}{2} = 10.5$   
 So,  $T \doteq 4.5 \sin \frac{\pi}{6}(t - 10.5) + 11.5$

**b** Last line should be:  
 $\frac{\pi}{6}(1.44 - (-10.5)) \doteq 6.25 \doteq 2\pi$

page 290 **Exercise 13C**

**3** Solution should finish:  
 At min.,  $t = 8$ , and at max.,  $t = 1 + 12 = 13$   
 $\therefore C = \frac{8+13}{2} = 10.5$   
 So,  $T \doteq 9.5 \sin \frac{\pi}{6}(t - 10.5) - 9.5$  ..... (1)  
 From technology,  $T \doteq 13.1 \sin(0.345t + 2.37) - 5.43$   
 i.e.,  $T \doteq 13.1 \sin 0.345(t + 6.87) - 5.43$  ..... (2)

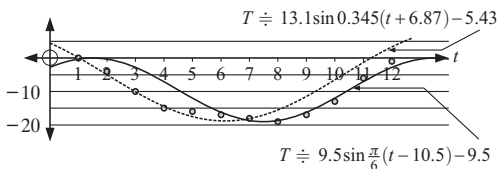

The model does not seem appropriate.

**4 a** Solution should finish:  
 $\therefore t = 6.2$  corresponds to 'high tide'  
 $\therefore C = \frac{0+6.2}{2} = 3.1$   
 So,  $H \doteq 7 \sin 0.507(t - 3.1) + 0$   
 i.e.,  $H \doteq 7 \sin 0.507(t - 3.1)$

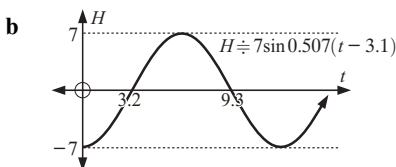

page 316 **Review set 13A**

**3** Solution should finish:  
 $C = \frac{7+14}{2} = 10.5$  {values of  $t$  at min. and max.}  
 So,  $T \doteq 7.05 \sin \frac{\pi}{6}(t - 10.5) + 24.75$   
 From technology,  $T \doteq 7.21 \sin(0.488t + 1.082) + 24.75$   
 i.e.,  $T \doteq 7.21 \sin 0.488(t + 2.22) + 24.75$   
**Note:**  $0.488(2.22 - (-10.5)) \doteq 6.21 \doteq 2\pi$

page 328 **Exercise 14E.2**

**5 b** Question should finish:  

$$= \begin{bmatrix} 78\,669.5 \\ 65\,589 \end{bmatrix} \begin{array}{l} \text{income from day 1} \\ \text{income from day 2} \end{array}$$

page 454 **Exercise 17B.2**

**2 b** Question should finish:  
 $\therefore \begin{bmatrix} x \\ y \end{bmatrix} = \begin{bmatrix} -2 \\ 6 \end{bmatrix} + \frac{t}{10} \begin{bmatrix} 20 \\ 15 \end{bmatrix}$

page 456 **Exercise 17B.3**

**3 a**  $\begin{bmatrix} -3 \\ 4 \end{bmatrix}$  has length  $\sqrt{(-3)^2 + 4^2} = 5$   
 $\therefore$  unit direction vector is  $\frac{1}{5} \begin{bmatrix} -3 \\ 4 \end{bmatrix}$   
 $\therefore$  the velocity vector is  $\frac{1}{5} \begin{bmatrix} -3 \\ 4 \end{bmatrix} \times 10 = \begin{bmatrix} -6 \\ 8 \end{bmatrix} = -6\mathbf{i} + 8\mathbf{j}$

page 532 **Exercise 19L**

**1** Last two lines should end:  

$$= \frac{{}_2C_2 \times {}_9C_2}{{}_{11}C_4}$$

$$= 0.109$$

page 533 **Exercise 19L**

**5 a**

2	3	2	1	1
---	---	---	---	---

  
 there are  $2 \times 3!$  seating arrangements if K and U sit at the ends.  
 $\therefore P(\text{K and U sit at the ends}) = \frac{2 \times 3!}{5!} = \frac{1}{10}$

page 631 **Exercise 23C**

**2 h** Question should finish:  
 $\therefore \frac{dy}{dx} = \frac{\frac{1}{x}}{\ln x} = \frac{1}{x \ln x}$

page 659 **Exercise 24D**

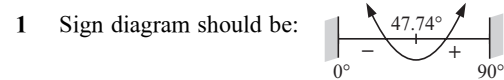

page 698 **Exercise 24C**

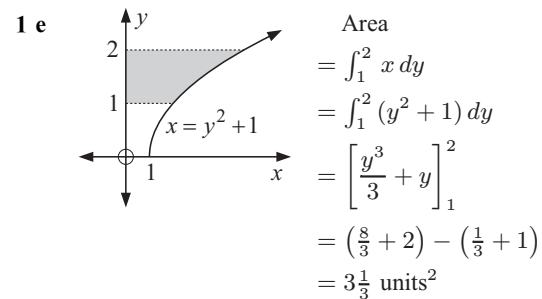

page 703 **Exercise 26C**

**7 b** Fourth line should be:  
 Area =  $\int_0^2 [0 - (-x^3 + 6x^2 - 8x)] dx$   
 $+ \int_2^4 [(-x^3 + 6x^2 - 8x) - 0] dx$